

Section 7. Resets

HIGHLIGHTS

This section of the manual contains the following topics:

7.1	Introduction.....	7-2
7.2	Control Registers.....	7-3
7.3	Modes of Operation.....	7-6
7.4	Effects of Various Resets.....	7-10
7.5	Related Application Notes.....	7-12
7.6	Revision History.....	7-13

Note: This family reference manual section is meant to serve as a complement to device data sheets. Depending on the device variant, this manual section may not apply to all PIC32 devices.

Please consult the note at the beginning of the “Resets” chapter in the current device data sheet to check whether this document supports the device you are using.

Device data sheets and family reference manual sections are available for download from the Microchip Worldwide Web site at: <http://www.microchip.com>

7.1 INTRODUCTION

The Resets module combines all Reset sources and controls the system Reset signal SYSRST. The following is a list of device Reset sources:

- POR: Power-on Reset
- MCLR: Pin Reset
- SWR: Software Reset
- WDTR: Watchdog Timer Reset
- BOR: Brown-out Reset
- CMR: Configuration Mismatch Reset

A simplified block diagram of the Reset module is shown in Figure 7-1. Any active source of Reset will make the system Reset signal active. Many registers associated with the CPU and peripherals are forced to a known “Reset state”. Most registers are unaffected by a Reset; their status is unknown on POR and unchanged by all other Resets.

Note: For register Reset states, refer to the specific peripheral or Section 2. “CPU” (DS61113) of the “PIC32 Family Reference Manual”.

Figure 7-1: System Reset Block Diagram

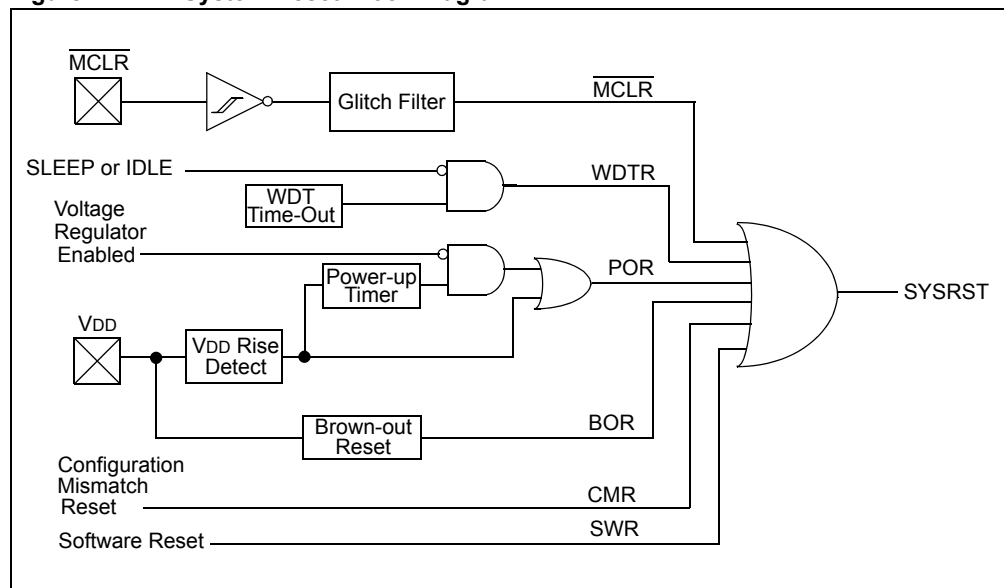

7.2 CONTROL REGISTERS

All types of device Resets will set corresponding Status bits in the RCON register to indicate the type of Reset (see [Register 7-1](#)). A Power-on Reset will clear all bits, except for the BOR and POR bits (RCON<1:0>), which are set. The user software may set or clear any of the bits at any time during code execution. The RCON bits serve only as Status bits. Setting a particular Reset status bit in software will not cause a system Reset to occur.

The RCON register also has other bits associated with the Watchdog Timer and device power-saving states. For more information on the function of these bits, refer to [7.4.3 “Using the RCON Status Bits”](#).

The RSWRST control register has only one bit, SWRST. This bit is used to force a software Reset condition.

The Resets module consists of the following Special Function Registers (SFRs):

- **RCON: Reset Control Register**
- **RSWRST: Software Reset Register**

[Table 7-1](#) summarizes all Resets-related registers. Corresponding registers appear after the summary, followed by a detailed description of each register.

Table 7-1: Reset SFR Summary

Name	Bit Range	Bit 31/23/15/7	Bit 30/22/14/6	Bit 29/21/13/5	Bit 28/20/12/4	Bit 27/19/11/3	Bit 26/18/10/2	Bit 25/17/9/1	Bit 24/16/8/0
RCON ^(1,2,3)	31:24	—	—	—	—	—	—	—	—
	23:16	—	—	—	—	—	—	—	—
	15:8	—	—	—	—	—	—	CMR	VREGS
	7:0	EXTR	SWR	—	WDTO	SLEEP	IDLE	BOR	POR
RSWRST ^(1,2,3)	31:24	—	—	—	—	—	—	—	—
	23:16	—	—	—	—	—	—	—	—
	15:8	—	—	—	—	—	—	—	—
	7:0	—	—	—	—	—	—	—	SWRST

Legend: — = unimplemented, read as '0'. Address offset values are shown in hexadecimal.

- Note 1:** This register has an associated Clear register at an offset of 0x4 bytes. The Clear register has the same name with CLR appended to the register name (e.g., RCONCLR). Writing a '1' to any bit position in the Clear register will clear valid bits in the associated register. Reads from the Clear register should be ignored.
- 2:** This register has an associated Set register at an offset of 0x8 bytes. The Set register has the same name with SET appended to the register name (e.g., RCONSET). Writing a '1' to any bit position in the Set register will set valid bits in the associated register. Reads from the Set register should be ignored.
- 3:** This register has an associated Invert register at an offset of 0xC bytes. The Invert register has the same name with INV appended to the register name (e.g., RCONINV). Writing a '1' to any bit position in the Invert register will invert valid bits in the associated register. Reads from the Invert register should be ignored.

PIC32 Family Reference Manual

Register 7-1: RCON: Reset Control Register

Bit Range	Bit 31/23/15/7	Bit 30/22/14/6	Bit 29/21/13/5	Bit 28/20/12/4	Bit 27/19/11/3	Bit 26/18/10/2	Bit 25/17/9/1	Bit 24/16/8/0
31:24	U-0	U-0	U-0	U-0	U-0	U-0	U-0	U-0
	—	—	—	—	—	—	—	—
23:16	U-0	U-0	U-0	U-0	U-0	U-0	U-0	U-0
	—	—	—	—	—	—	—	—
15:8	U-0	U-0	U-0	U-0	U-0	U-0	R/W-x	R/W-x
	—	—	—	—	—	—	CMR ^(1,3)	VREGS
7:0	R/W-0	R/W-0	U-0	R/W-0	R/W-0	R/W-0	R/W-1	R/W-1
	EXTR ^(1,3)	SWR ^(1,3)	—	WDTO ^(1,3)	SLEEP ^(1,3)	IDLE ^(1,3)	BOR ^(1,3)	POR ^(1,2,3)

Legend:

R = Readable bit	W = Writable bit	U = Unimplemented bit, read as '0'
-n = Value at POR	'1' = Bit is set	'0' = Bit is cleared
		x = Bit is unknown

bit 31-10 **Unimplemented:** Read as '0'

bit 9 **CMR:** Configuration Mismatch Flag bit^(1,3)
 1 = A Configuration mismatch Reset has occurred
 0 = A Configuration mismatch Reset has not occurred

bit 8 **VREGS:** Voltage Regulator Standby Enable bit
 1 = Regulator is enabled and is on during Sleep mode
 0 = Regulator is disabled and is off during Sleep mode

bit 7 **EXTR:** External Reset (MCLR) Pin Flag bit^(1,3)
 1 = A Master Clear (pin) Reset has occurred
 0 = A Master Clear (pin) Reset has not occurred

bit 6 **SWR:** Software Reset Flag bit^(1,3)
 1 = A Software Reset was executed
 0 = A Software Reset as not executed

bit 5 **Unimplemented:** Read as '0'

bit 4 **WDTO:** WDT Time-out Flag bit^(1,3)
 1 = WDT Time-out has occurred
 0 = WDT Time-out has not occurred

bit 3 **SLEEP:** Wake From Sleep Flag bit^(1,3)
 1 = Device was in Sleep mode
 0 = Device was not in Sleep mode

bit 2 **IDLE:** Wake From Idle Flag bit^(1,3)
 1 = Device was in Idle mode
 0 = Device was not in Idle mode

bit 1 **BOR:** Brown-out Reset Flag bit^(1,2,3)
 User software must clear this bit to view next detection.
 1 = Brown-out Reset has occurred
 0 = Brown-out Reset has not occurred

bit 0 **POR:** Power-on Reset Flag bit^(1,2,3)
 User software must clear this bit to view next detection.
 1 = Power-on Reset has occurred
 0 = Power-on Reset has not occurred

Note 1: The RCON flag bits only serve as status bits. Setting a particular Reset status bit in software will not cause a device Reset to occur.

2: The BOR bit is also set after a Power-on Reset.

3: This bit is set in hardware; it can only be cleared (=0) in software.

Register 7-2: RSWRST: Software Reset Register

Bit Range	Bit 31/23/15/7	Bit 30/22/14/6	Bit 29/21/13/5	Bit 28/20/12/4	Bit 27/19/11/3	Bit 26/18/10/2	Bit 25/17/9/1	Bit 24/16/8/0
31:24	U-0	U-0	U-0	U-0	U-0	U-0	U-0	U-0
	—	—	—	—	—	—	—	—
23:16	U-0	U-0	U-0	U-0	U-0	U-0	U-0	U-0
	—	—	—	—	—	—	—	—
15:8	U-0	U-0	U-0	U-0	U-0	U-0	U-0	U-0
	—	—	—	—	—	—	—	—
7:0	U-0	U-0	U-0	U-0	U-0	U-0	U-0	W-0
	—	—	—	—	—	—	—	SWRST ⁽¹⁾

Legend:

R = Readable bit W = Writable bit U = Unimplemented bit, read as '0'
 -n = Value at POR '1' = Bit is set '0' = Bit is cleared x = Bit is unknown

- bit 31-1 **Unimplemented:** Read as '0'
- bit 0 **SWRST:** Software Reset Trigger bit⁽¹⁾
 - 1 = Enable software Reset event
 - 0 = No effect

Note 1: The system unlock sequence must be performed before the SWRST bit can be written. A read must follow the write of this bit to generate a Reset. See [7.3.4 “Software Reset \(SWR\)”](#) for more information.

7.3 MODES OF OPERATION

7.3.1 System Reset (SYSRST)

The PIC32 Internal System Reset (SYSRST) can be generated from multiple Reset sources, such as:

- POR (Power-on Reset)
- BOR (Brown-out Reset)
- $\overline{\text{MCLR}}$ (Master Clear Reset)
- WDTO (Watchdog Time-out Reset)
- SWR (Software Reset)
- CMR (Configuration Mismatch Reset)

A system Reset is active at the first POR and asserted until device configuration settings are loaded and the oscillator clock sources become stable. The system Reset is then deasserted allowing the CPU to start fetching code after eight system clock cycles (SYSCLK).

BOR, $\overline{\text{MCLR}}$ and WDTO Resets are asynchronous events, and to avoid SFR and RAM corruptions, the system Reset is synchronized with the system clock. All other Reset events are synchronous.

7.3.2 Power-on Reset (POR)

A power-on event generates an internal Power-on Reset pulse when a VDD rise is detected above VPOR. The device supply-voltage-characteristics must meet the specified starting-voltage and rise-rate requirements to generate the POR pulse. In particular, VDD must fall below VPOR before a new POR is initiated. For more information on the VPOR and VDD rise-rate specifications, refer to the “**Electrical Characteristics**” chapter of the specific device data sheet.

For those PIC32 devices that have the on-chip voltage regulator enabled, the Power-up Timer (PWRT) is automatically disabled. For those PIC32 devices that have the on-chip voltage regulator disabled, the core is supplied from an external power supply and the Power-up Timer is automatically enabled and is used to extend the duration of a power-up sequence. The PWRT adds a fixed 64 ms nominal delay at device start-up. Therefore, the Power-on delay can either be the on-chip voltage regulator output delay, designated as TPU, or the power-up timer delay, designated as TPWRT.

At this point the POR event has expired, but the device Reset is still asserted while device configuration settings are loaded and the clock oscillator sources are configured. The clock monitoring circuitry waits for the oscillator source to become stable. The clock source used by PIC32 devices when exiting from Reset, is always selected from the FNOSC<2:0> bits (DEVCFG1<2:0>). This additional delay depends on the clock and can include delays for TOSC, TLOCK and TFSCM. For details on the oscillator, PLL and Fail-Safe Clock Monitoring (FSCM), see **6.3.5 “Fail-Safe Clock Monitor Operation”** in **Section 6. “Oscillator”** (DS61112).

After these delays expire, the system Reset SYSRST is de-asserted. Before allowing the CPU to start code execution, eight system clock cycles are required before the synchronized Reset to the CPU core is deasserted.

The power-on event sets the BOR and POR status bits (RCON<1:0>).

For more information on the values of the delay parameters, refer to the “**Electrical Characteristics**” chapter of the specific device data sheet.

Note: When the device exits the Reset condition (begins normal operation), the device operating parameters (voltage, frequency, temperature, etc.) must be within their operating ranges; otherwise, the device will not function correctly. The user software must ensure that the delay between the time power is first applied and the time system Reset is released is long enough to get all operating parameters within the specification.

7.3.3 Master Clear ($\overline{\text{MCLR}}$) Reset

Whenever the Master Clear pin ($\overline{\text{MCLR}}$) is driven low, the Reset event is synchronized with the system clock, SYSClk, before asserting the system Reset, SYSRST, provided the input pulse on $\overline{\text{MCLR}}$ is longer than a certain minimum width, as specified in the “**Electrical Characteristics**” chapter of the specific device data sheet.

The $\overline{\text{MCLR}}$ pin provides a filter to minimize the effects of noise and to avoid unwanted Reset events. The EXTR Status bit (RCON<7>) is set to indicate the MCLR Reset.

7.3.4 Software Reset (SWR)

The PIC32 CPU core does not provide a specific RESET instruction; however, a hardware Reset can be performed in software (software Reset) by executing a software Reset command sequence. The software Reset acts like a MCLR Reset. The software Reset sequence requires the system unlock sequence to be executed before the SWRST bit (RSWRST<0>) can be written. For system unlock details, see 6.3.6 “Clock Switching Operation” in Section 6. “Oscillator” (DS61112).

A software Reset is performed as follows:

1. Write the system unlock sequence.
2. Set the SWRST bit (RSWRST<0>) = 1.
3. Read the RSWRST register.

Follow with “while(1);” or four “NOP” instructions.

Writing a ‘1’ to the RSWRST register sets the SWRST bit, arming the software Reset. The subsequent read of the RSWRST register triggers the software Reset, which should occur on the next clock cycle following the read operation. To ensure no other user code is executed before the Reset event occurs, it is recommended that four “NOP” instructions or a “while(1);” statement is placed after the READ instruction.

The SWR Status bit (RCON<6>) is set to indicate the Software Reset.

Example 7-1: Software Reset Command Sequence

```

/* The following code illustrates a software Reset */
// assume interrupts are disabled
// assume the DMA controller is suspended
// assume the device is locked
/* perform a system unlock sequence */
// starting critical sequence
SYSKEY = 0x00000000; //write invalid key to force lock
SYSKEY = 0xAA996655 //write key1 to SYSKEY
SYSKEY = 0x556699AA //write key2 to SYSKEY
// OSCCON is now unlocked
/* set SWRST bit to arm reset */
RSWRSTSET = 1;

/* read RSWRST register to trigger reset */
unsigned int dummy;
dummy = RSWRST;
/* prevent any unwanted code execution until reset occurs*/
while(1);

```

7.3.5 Watchdog Timer Reset

A Watchdog Timer (WDT) Reset event is synchronized with the system clock, SYSClk, before asserting the system Reset.

Note: A WDT time-out during Sleep or Idle mode will wake-up the processor and branch to the PIC32 reset vector, but does not Reset the processor.

The only bits affected are WDTO, and SLEEP or IDLE in the RCON register. For more information on the WDT reset, refer to Section 9. “Watchdog Timer and Power-up Timer” (DS61114).

7.3.6 Brown-out Reset (BOR)

PIC32 family devices have a simple Brown-out Reset (BOR) capability. If the voltage supplied to the regulator is inadequate to maintain a regulated level, the regulator Reset circuitry will generate a BOR event, which is synchronized with the system clock, SYCLK, before asserting the system Reset. This event is captured by the BOR flag bit (RCON<1>). Refer to the “**Electrical Characteristics**” chapter of the specific device data sheet for further details.

7.3.7 Configuration Mismatch Reset (CMR)

To maintain the integrity of the stored configuration values, all device Configuration bits are loaded and implemented as a complementary set of bits. As the Configuration Words are being loaded, for each bit loaded as '1', a complementary value of '0' is stored into its corresponding background word location and vice versa. The bit pairs are compared every time the Configuration Words are loaded, including Sleep mode. During this comparison, if the Configuration bit values are not found opposite to each other, a configuration mismatch event is generated, which causes a device Reset.

If a device Reset occurs as a result of a configuration mismatch, the CMR Status bit (RCON<9>) is set.

7.3.8 Determining the Source of Device Reset

After a device Reset, the RCON register can be examined by initialization code to confirm the source of the reset. In certain applications, this information can be used to take appropriate action to correct the problem that caused the reset to occur.

All reset status bits in the RCON register should be cleared after reading them to ensure the RCON value will provide meaningful results after the next device Reset.

[Example 7-2](#) illustrates how to determine the source of device Reset using the RCON register.

Example 7-2: Determining the Source of Device Reset

```
int main(void)
{
    //... perform application specific startup tasks

    // next, check the cause of the Reset
    if(RCON & 0x0003)
    {
        // execute a Power-on Reset handler
        // ...
    }
    else if(RCON & 0x0002)
    {
        // execute a Brown-out Reset handler
        // ...
    }
    else if(RCON & 0x0080)
    {
        // execute a Master Clear Reset handler
        // ...
    }
    else if(RCON & 0x0040)
    {
        // execute a Software Reset handler
        // ...
    }
    else if (RCON & 0x0200)
    {
        // execute a Configuration Mismatch Reset handler
        // ...
    }
    else if (RCON & 0x0010)
    {
        // execute Watchdog Time-out Reset handler
        // ...
    }

    //... perform other application specific tasks

    while(1);
}
```

PIC32 Family Reference Manual

7.4 EFFECTS OF VARIOUS RESETS

The Reset value for the Reset Control register, RCON, will depend on the type of device Reset, as indicated in [Table 7-2](#).

Table 7-2: Status Bits, Their Significance and the Initialization Condition for RCON Register

Condition	Program Counter	EXTR	SWR	WDTO	SLEEP	IDLE	CMR	BOR	POR
Power-on Reset	0xBFC0_0000	0	0	0	0	0	0	1	1
Brown-out Reset		0	0	0	0	0	0	1	u
MCLR Reset during Run Mode		1	u	u	u	u	u	u	u
MCLR Reset during Idle Mode		1	u	u	u	1 ⁽¹⁾	u	u	u
MCLR Reset during Sleep Mode		1	u	u	1 ⁽¹⁾	u	u	u	u
Software Reset Command		u	1	u	u	u	u	u	u
Configuration Word Mismatch Reset		u	u	u	u	u	1	u	u
WDT Time-out Reset during Run Mode		u	u	1	u	u	u	u	u
WDT Time-out Reset during Idle Mode		u	u	1	u	1 ⁽¹⁾	u	u	u
WDT Time-out Reset during Sleep Mode		u	u	1	1 ⁽¹⁾	u	u	u	u
Interrupt Exit from Idle Mode	Vector	u	u	u	u	1 ⁽¹⁾	u	u	u
Interrupt Exit from Sleep Mode		u	u	u	1 ⁽¹⁾	u	u	u	u

Legend: u = unchanged

Note 1: SLEEP and IDLE bits states are defined by previously executed `WAIT` instructions.

7.4.1 Special Function Register (SFR) Reset States

Most of the SFRs associated with the PIC32 CPU and peripherals are reset to a particular value at a device Reset. Reset values are specified in [Table 7-2](#).

The Reset value for the Reset Control register, RCON, will depend on the type of device Reset.

7.4.2 Configuration Word Register Reset States

All Reset conditions force the configuration settings to be reloaded. The POR sets all the Configuration Word register locations to a '1' before loading the configuration settings. For all other Reset conditions, the Configuration Word register locations are not reset prior to being reloaded. This difference in behavior accommodates MCLR assertions during Debug mode without affecting the state of the Debug operations.

Independent of the source of a Reset, the system clock is always reloaded and is specified by the `FNOSC<2:0>` bits (`DEVCFG<2:0>`). When the device is executing code, the user software may change the primary system clock source by using the `OSCCON` register. For more information, refer to [Section 6. "Oscillator"](#) (DS61112).

7.4.3 Using the RCON Status Bits

The user software can read the RCON register after any system Reset to determine the cause of the Reset. [Table 7-3](#) provides a summary of the Reset flag bit operation.

Note: The Status bits in the RCON register should be cleared after they are read so that the next RCON register value after a device Reset will be meaningful.

Table 7-3: Reset Flag Bit Operation

Flag Bit ⁽¹⁾	Set by	Cleared by
POR (RCON<0>)	POR	User Software
BOR (RCON<1>)	POR, BOR	User Software
EXTR (RCON<7>)	MCLR Reset	User Software, POR, BOR
SWR (RCON<6>)	Software Reset command	User Software, POR, BOR
CMR (RCON<9>)	Configuration mismatch	User Software, POR, BOR
WDTO (RCON<4>)	WDT time-out	User Software, POR, BOR
SLEEP (RCON<3>)	WAIT instruction	User Software, POR, BOR
IDLE (RCON<2>)	WAIT instruction	User Software, POR, BOR

Note 1: All Reset flag bits may be set or cleared by the user software.

7.4.4 Device Reset to Code Execution Start Time

The delay between the end of a Reset event and when the device actually begins to execute code is determined by two main factors: the type of Reset, and the system clock source coming out of the Reset. The code execution start time for various types of device Resets are summarized in [Table 7-4](#). Individual delays are characterized in the “**Electrical Characteristics**” chapter of the specific device data sheet.

Table 7-4: Code Execution Start Time for Various Device Resets

Reset Type	Clock Source	Power-Up Delay ^(1,2,3,4)	System Clock Delay ^(1,5,6)	FSCM Delay ^(1,7)
POR	EC, FRC, FRCDIV, LPRC	(TPU OR TPWRT) + TSYSDLY	—	—
	ECPLL, FRCPLL	(TPU OR TPWRT) + TSYSDLY	TLOCK	TFSCM
	XT, HS, SOSC	(TPU OR TPWRT) + TSYSDLY	TOST	TFSCM
	XTPLL, HSPLL	(TPU OR TPWRT) + TSYSDLY	TOST + TLOCK	TFSCM
BOR	EC, FRC, FRCDIV, LPRC	TSYSDLY	—	—
	ECPLL, FRCPLL	TSYSDLY	TLOCK	TFSCM
	XT, HS, SOSC	TSYSDLY	TOST	TFSCM
	XTPLL	TSYSDLY	TOST + TLOCK	TFSCM
MCLR, CMR, SWR, WDTO	Any Clock	TSYSDLY	—	—

Note 1: For parameter specifications, see the “**Electrical Characteristics**” chapter of the specific device data sheet.

2: TPU = Power-up Period with on-chip regulator enabled.

3: TPWRT = Power-up Period (Power-up Timer) with on-chip regulator disabled.

4: TSYSDLY = Time required to reload Device Configuration Fuses plus 8 SYSClk cycles.

5: TOST = Oscillator Start-up Timer.

6: TLOCK = PLL lock time.

7: TFSCM = Fail-Safe Clock Monitor delay.

7.5 RELATED APPLICATION NOTES

This section lists application notes that are related to this section of the manual. These application notes may not be written specifically for the PIC32 device family, but the concepts are pertinent and could be used with modification and possible limitations. The current application notes related to Resets are:

Title	Application Note #
No related application notes at this time.	N/A

Note: Please visit the Microchip web site (www.microchip.com) for additional application notes and code examples for the PIC32 family of devices.

7.6 REVISION HISTORY

Revision A (September 2007)

- This is the initial released version of this document.

Revision B (October 2007)

- Updated document to remove Confidential status.

Revision C (April 2008)

- Revised status to Preliminary; Revised U-0 to r-x.

Revision D (June 2008)

- Revised Figure 7-2; Deleted Figure 7-3; Revised Sections 7.3.2, 7.3.3, 7.3.4; Revised Table 7-4; Delete Figure 7.2 and 7.3; Change Reserved bits from “Maintain as” to “Write”.

Revision E (July 2008)

- Revised Section 7.3.2, 7.3.3, 7.3.6, 7.4.4.

Revision F (October 2011)

This revision includes the following updates:

- Added a Note at the beginning of the section, which provides information on the complementary documentation
- Changed the document running header from PIC32MX Family Reference Manual to PIC32 Family Reference Manual
- Changed all occurrences of PIC32MX to PIC32
- Removed the following Clear, Set and Invert registers:
 - RCONCLR: Reset Control Clear Register
 - RCONSET: Reset Control Set Register
 - RONINV: Reset Control Invert Register
 - RSWRSTCLR: Software Reset Clear Register
 - RSWRSTSET: Software Reset Set Register
 - RSWRSTINV: Software Reset Invert Register
- Added Notes to [Register 7-1](#) and [Register 7-2](#) describing their corresponding Set, Clear and Invert registers
- Updated all r-x bits as U-0 bits in [Register 7-1](#) and [Register 7-2](#)
- Updated [Example 7-1](#)
- Relocated and renamed 7.5 “Design Tips” to **7.3.8 “Determining the Source of Device Reset”**
- Modifications to register formatting and minor text updates have been made throughout the document

NOTES:

Note the following details of the code protection feature on Microchip devices:

- Microchip products meet the specification contained in their particular Microchip Data Sheet.
- Microchip believes that its family of products is one of the most secure families of its kind on the market today, when used in the intended manner and under normal conditions.
- There are dishonest and possibly illegal methods used to breach the code protection feature. All of these methods, to our knowledge, require using the Microchip products in a manner outside the operating specifications contained in Microchip's Data Sheets. Most likely, the person doing so is engaged in theft of intellectual property.
- Microchip is willing to work with the customer who is concerned about the integrity of their code.
- Neither Microchip nor any other semiconductor manufacturer can guarantee the security of their code. Code protection does not mean that we are guaranteeing the product as “unbreakable.”

Code protection is constantly evolving. We at Microchip are committed to continuously improving the code protection features of our products. Attempts to break Microchip's code protection feature may be a violation of the Digital Millennium Copyright Act. If such acts allow unauthorized access to your software or other copyrighted work, you may have a right to sue for relief under that Act.

Information contained in this publication regarding device applications and the like is provided only for your convenience and may be superseded by updates. It is your responsibility to ensure that your application meets with your specifications. MICROCHIP MAKES NO REPRESENTATIONS OR WARRANTIES OF ANY KIND WHETHER EXPRESS OR IMPLIED, WRITTEN OR ORAL, STATUTORY OR OTHERWISE, RELATED TO THE INFORMATION, INCLUDING BUT NOT LIMITED TO ITS CONDITION, QUALITY, PERFORMANCE, MERCHANTABILITY OR FITNESS FOR PURPOSE. Microchip disclaims all liability arising from this information and its use. Use of Microchip devices in life support and/or safety applications is entirely at the buyer's risk, and the buyer agrees to defend, indemnify and hold harmless Microchip from any and all damages, claims, suits, or expenses resulting from such use. No licenses are conveyed, implicitly or otherwise, under any Microchip intellectual property rights.

Trademarks

The Microchip name and logo, the Microchip logo, dsPIC, KEELOQ, KEELOQ logo, MPLAB, PIC, PICmicro, PICSTART, PIC³² logo, rPIC and UNI/O are registered trademarks of Microchip Technology Incorporated in the U.S.A. and other countries.

FilterLab, Hampshire, HI-TECH C, Linear Active Thermistor, MXDEV, MXLAB, SEEVAL and The Embedded Control Solutions Company are registered trademarks of Microchip Technology Incorporated in the U.S.A.

Analog-for-the-Digital Age, Application Maestro, chipKIT, chipKIT logo, CodeGuard, dsPICDEM, dsPICDEM.net, dsPICworks, dsSPEAK, ECAN, ECONOMONITOR, FanSense, HI-TIDE, In-Circuit Serial Programming, ICSP, Mindi, MiWi, MPASM, MPLAB Certified logo, MPLIB, MPLINK, mTouch, Omniscient Code Generation, PICC, PICC-18, PICDEM, PICDEM.net, PICKit, PICtail, REAL ICE, rLAB, Select Mode, Total Endurance, TSHARC, UniWinDriver, WiperLock and ZENA are trademarks of Microchip Technology Incorporated in the U.S.A. and other countries.

SQTP is a service mark of Microchip Technology Incorporated in the U.S.A.

All other trademarks mentioned herein are property of their respective companies.

© 2007-2011, Microchip Technology Incorporated, Printed in the U.S.A., All Rights Reserved.

 Printed on recycled paper.

ISBN: 978-1-61341-707-2

QUALITY MANAGEMENT SYSTEM
CERTIFIED BY DNV
== ISO/TS 16949:2009 ==

Microchip received ISO/TS-16949:2009 certification for its worldwide headquarters, design and wafer fabrication facilities in Chandler and Tempe, Arizona; Gresham, Oregon and design centers in California and India. The Company's quality system processes and procedures are for its PIC[®] MCUs and dsPIC[®] DSCs, KEELOQ[®] code hopping devices, Serial EEPROMs, microperipherals, nonvolatile memory and analog products. In addition, Microchip's quality system for the design and manufacture of development systems is ISO 9001:2000 certified.



MICROCHIP

Worldwide Sales and Service

AMERICAS

Corporate Office
2355 West Chandler Blvd.
Chandler, AZ 85224-6199
Tel: 480-792-7200
Fax: 480-792-7277
Technical Support:
<http://www.microchip.com/support>
Web Address:
www.microchip.com

Atlanta
Duluth, GA
Tel: 678-957-9614
Fax: 678-957-1455

Boston
Westborough, MA
Tel: 774-760-0087
Fax: 774-760-0088

Chicago
Itasca, IL
Tel: 630-285-0071
Fax: 630-285-0075

Cleveland
Independence, OH
Tel: 216-447-0464
Fax: 216-447-0643

Dallas
Addison, TX
Tel: 972-818-7423
Fax: 972-818-2924

Detroit
Farmington Hills, MI
Tel: 248-538-2250
Fax: 248-538-2260

Indianapolis
Noblesville, IN
Tel: 317-773-8323
Fax: 317-773-5453

Los Angeles
Mission Viejo, CA
Tel: 949-462-9523
Fax: 949-462-9608

Santa Clara
Santa Clara, CA
Tel: 408-961-6444
Fax: 408-961-6445

Toronto
Mississauga, Ontario,
Canada
Tel: 905-673-0699
Fax: 905-673-6509

ASIA/PACIFIC

Asia Pacific Office
Suites 3707-14, 37th Floor
Tower 6, The Gateway
Harbour City, Kowloon
Hong Kong
Tel: 852-2401-1200
Fax: 852-2401-3431

Australia - Sydney
Tel: 61-2-9868-6733
Fax: 61-2-9868-6755

China - Beijing
Tel: 86-10-8569-7000
Fax: 86-10-8528-2104

China - Chengdu
Tel: 86-28-8665-5511
Fax: 86-28-8665-7889

China - Chongqing
Tel: 86-23-8980-9588
Fax: 86-23-8980-9500

China - Hangzhou
Tel: 86-571-2819-3187
Fax: 86-571-2819-3189

China - Hong Kong SAR
Tel: 852-2401-1200
Fax: 852-2401-3431

China - Nanjing
Tel: 86-25-8473-2460
Fax: 86-25-8473-2470

China - Qingdao
Tel: 86-532-8502-7355
Fax: 86-532-8502-7205

China - Shanghai
Tel: 86-21-5407-5533
Fax: 86-21-5407-5066

China - Shenyang
Tel: 86-24-2334-2829
Fax: 86-24-2334-2393

China - Shenzhen
Tel: 86-755-8203-2660
Fax: 86-755-8203-1760

China - Wuhan
Tel: 86-27-5980-5300
Fax: 86-27-5980-5118

China - Xian
Tel: 86-29-8833-7252
Fax: 86-29-8833-7256

China - Xiamen
Tel: 86-592-2388138
Fax: 86-592-2388130

China - Zhuhai
Tel: 86-756-3210040
Fax: 86-756-3210049

ASIA/PACIFIC

India - Bangalore
Tel: 91-80-3090-4444
Fax: 91-80-3090-4123

India - New Delhi
Tel: 91-11-4160-8631
Fax: 91-11-4160-8632

India - Pune
Tel: 91-20-2566-1512
Fax: 91-20-2566-1513

Japan - Yokohama
Tel: 81-45-471- 6166
Fax: 81-45-471-6122

Korea - Daegu
Tel: 82-53-744-4301
Fax: 82-53-744-4302

Korea - Seoul
Tel: 82-2-554-7200
Fax: 82-2-558-5932 or
82-2-558-5934

Malaysia - Kuala Lumpur
Tel: 60-3-6201-9857
Fax: 60-3-6201-9859

Malaysia - Penang
Tel: 60-4-227-8870
Fax: 60-4-227-4068

Philippines - Manila
Tel: 63-2-634-9065
Fax: 63-2-634-9069

Singapore
Tel: 65-6334-8870
Fax: 65-6334-8850

Taiwan - Hsin Chu
Tel: 886-3-5778-366
Fax: 886-3-5770-955

Taiwan - Kaohsiung
Tel: 886-7-536-4818
Fax: 886-7-330-9305

Taiwan - Taipei
Tel: 886-2-2500-6610
Fax: 886-2-2508-0102

Thailand - Bangkok
Tel: 66-2-694-1351
Fax: 66-2-694-1350

EUROPE

Austria - Wels
Tel: 43-7242-2244-39
Fax: 43-7242-2244-393

Denmark - Copenhagen
Tel: 45-4450-2828
Fax: 45-4485-2829

France - Paris
Tel: 33-1-69-53-63-20
Fax: 33-1-69-30-90-79

Germany - Munich
Tel: 49-89-627-144-0
Fax: 49-89-627-144-44

Italy - Milan
Tel: 39-0331-742611
Fax: 39-0331-466781

Netherlands - Drunen
Tel: 31-416-690399
Fax: 31-416-690340

Spain - Madrid
Tel: 34-91-708-08-90
Fax: 34-91-708-08-91

UK - Wokingham
Tel: 44-118-921-5869
Fax: 44-118-921-5820

08/02/11