

# An Inexpensive Field-Portable Programmable Potentiostat

Ashwini Vittal Gopinath and Dale Russell\*

*Department of Chemistry, Boise State University, Boise, ID 83725-1520, drussell@boisestate.edu*

*Received June 10, 2005. Accepted July 13, 2005.*

**Abstract:** The design and construction of a small, simple, rugged, inexpensive programmable potentiostat is presented. This experiment is intended for students in advanced analytical and integrated laboratory courses, in which students often study electronics and build instruments in order to better understand design, function, and optimization. It is also suitable for independent student projects in analytical instrumentation or electrochemistry, including projects involving field-portable electrochemical instrumentation. Advanced high school students interested in chemical instrumentation would find it within their ability as a special project provided they have a working knowledge of electronic circuits. This experiment requires students to use electronic devices and components, including op amps, to build a control circuit for electroanalytical experiments. The total cost of this potentiostat is less than \$50 making it cost effective for individual or small-group experiments and special projects. Potentiostat dimensions are 3 cm × 13 cm on a printed circuit board. The simple circuit presented here is solid state, amenable to battery-powered operation, and if interfaced to an appropriate electrochemical cell, can be used as a rugged, field-portable electrochemical sensor system for monitoring environmental contaminants. Test results using potassium ferricyanide in cyclic voltammetric mode are presented to show the operation of the instrument. Linear correlation of anodic and cathodic peak heights with analyte concentration is demonstrated though a range of concentrations with a correlation factor of greater than 0.99.

## Introduction

A review of the literature did not yield any simple, inexpensive, and low-power consumption designs for construction of a potentiostat; therefore, we offer this instrument design as a laboratory experiment or special project for more advanced students. Students in advanced analytical and integrated laboratory courses often study electronics and build instruments in order to better understand their design, function, and optimization. Students interested in analytical instrumentation or electrochemistry, including projects involving field-portable electrochemical instrumentation, might also find this potentiostat useful. It is also accessible to advanced high school students interested in chemical instrumentation provided they have a working knowledge of electronic circuits. Students will need to have a working knowledge of simple circuit design and construction, including the use of op amps. The total cost of this potentiostat is less than \$50 making it cost effective for individual or small group experiments and special projects. Potentiostat dimensions are 3 cm × 13 cm on a printed-circuit board (Figure 1). The simple circuit presented here is solid state, amenable to battery powered operation, and if interfaced to an appropriate electrochemical cell, can be used as a rugged, field-portable sensor system for monitoring environmental contaminants.

A potentiostat is used for electrochemical characterization of redox active species and in evaluating thermodynamic and kinetic parameters of electron transfer events. A potentiostat is an electronic instrument capable of imposing electrical potential waveforms across a working electrode relative to a reference electrode. It also measures the resultant current through the cell at a third electrode. Potentiostats are widely used electroanalytical techniques to identify, quantify, and characterize redox active species including inorganic, organic,

and biochemical species [1–3]. Electroanalytical methods requiring potentiostatic control of the experiment include analysis of corrosion (e.g., Tafel plots) [4], materials properties [5], and in vivo detection of biologicals such as glucose and catechol amines [6]. Cyclic voltammetry is one of the premier methods of determining thermodynamic and kinetic parameters of electron-transfer events, including such events in proteins. [7]

Commercially available potentiostats tend to be large in size and expensive (prices ranging from several hundred dollars to more than \$25,000). They also tend to be laboratory-based and not field-portable with a few exceptions such as the PalmSens and do not, for example, lend themselves to being carried into the back country for on-site measurements. For these reasons, it was desirable to design and build a small, rugged, inexpensive potentiostat to interface with various types of electrochemical probes.

In operation, the potentiostat is commonly interfaced to a three-electrode setup. Any electrode combination that meets the fundamental requirements of the electrochemistry being performed could in principle be used. The reference electrode should approach an ideal non-polarizable condition, examples being Ag/AgCl or calomel electrodes, because this electrode establishes a constant reference potential in the electrochemical cell, against which the working electrode potential may be determined with relatively high precision. This is critical because a change in peak location as small as 1.0 mV can be important in precise electrochemical measurements, for example, when determining thermodynamic or kinetic parameters for a redox system. While the nature of the reference electrode is important in ensuring the stability of its reference potential, the potentiostat design is also critical. Minimal current is drawn through the reference electrode because its current signal is made input to a very-high-

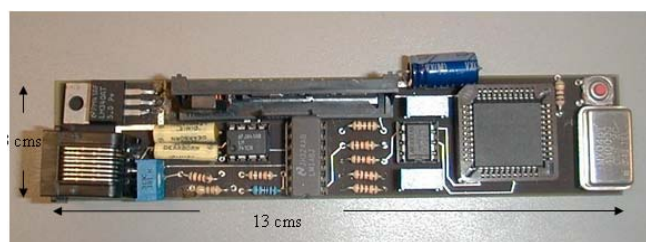

Figure 1. Potentiostat realized on the PCB, dimensions 13 cm × 3 cm.

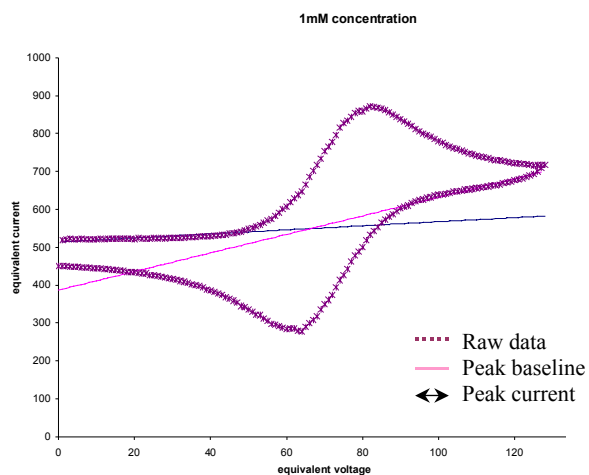

Figure 2. Representative  $i$  versus  $E$  curve.

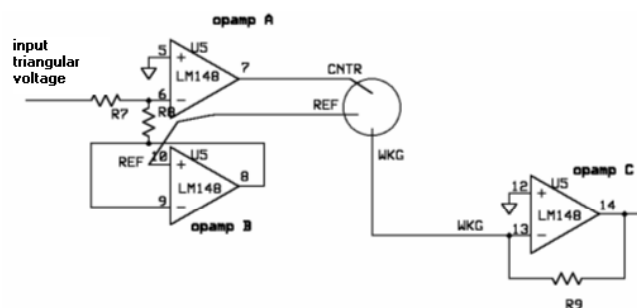

Figure 3. Basic schematic of a potentiostat circuit.

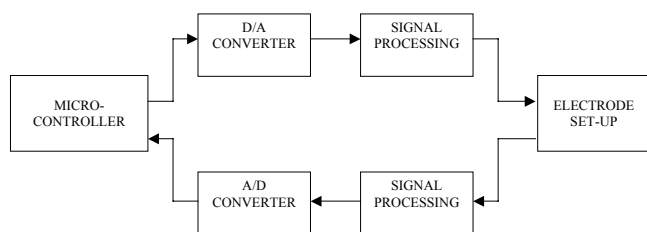

Figure 4. Basic block diagram of a microcontroller controlled potentiostat.

impedance electrometer (op amp), thus ensuring the constant potential condition.

The working electrode is the surface at which the electron transfer of interest occurs. For investigation of solution-phase species, the working electrode should approach an ideal polarizable electrode and should also be electrochemically inert. Exceptions to this condition occur when the working electrode itself is the system under analysis. Good choices for the working electrode material are the relatively inert metals

such as platinum and various forms of carbon (glassy carbon, graphite, and the like). For a very inexpensive working electrode “lead” (graphite) from a mechanical pencil may be used.

Current arising from the electron-transfer events at the working electrode is measured at the counter electrode and, therefore, this electrode must be geometrically larger than the working electrode so that it does not limit the current density at the working electrode. Electron-transfer events at the counter electrode surface are not usually of interest, and as long as they do not chemically interfere with the analysis, they can be ignored. If contaminants are likely to be produced at the counter electrode, it can be placed in a separate compartment from the analyte solution as long as a current pathway is provided between the compartments by, for example, a salt bridge or sintered-glass frit.

A potentiostat is used for a number of electroanalytical techniques, including cyclic voltammetry (CV). In CV, a triangular waveform is imposed between the reference and working electrodes and the resultant current through the cell is measured between the counter and working electrodes. Electron-transfer events show up as increased current with a characteristic hysteresis or “duck” shape in the  $i$  versus  $E$  curve as shown in Figure 2. Peak current increases with increasing concentration and also with increasing scan rate for the same concentration. If electrode kinetics are not rapid and reversible, the peaks may also separate from each other, and peak maxima (minima) shift in potential; therefore, a peak-finding algorithm is needed. This algorithm is included in an appendix. It actually finds the knee of the curve, where the current begins to rise above baseline. This is used to extrapolate the baseline current in order to calculate peak current, as described in the appendix.

Instructions are given below for construction of a microcontroller- (or microprocessor-) controlled potentiostat on a printed circuit board as a student laboratory exercise. The electrochemical testing of the potentiostat was carried out using potassium ferricyanide, which was chosen because it exhibits a rapid, reversible one-electron process.

## Experimental

**The Basic Potentiostat Circuit.** A basic potentiostat circuit, described in reference 8, is presented in Figure 3. The input triangular-voltage waveform is fed to a current buffer “opamp A” and to the reference electrode. In a current buffer, the input is isolated from the output and, thus, the current at the output of the op amp is not limited by input current and is capable of providing infinite current (effectively infinite, practically 1 A). This satisfies the basic requirement for a counter electrode, which needs to be able to provide any amount of current required by the electrochemical activity at the working electrode. The electrochemical current generated at the working electrode is converted into an equivalent voltage by “opamp C,” which is a current to voltage converter and can be measured using an oscilloscope or microcontroller circuitry. The reference electrode is tied to the input of “opamp B,” which has infinite input resistance (effectively “infinite,” in the range of Mega ohms) and hence there is very little current through the reference electrode.

Input to the potentiostat circuit can be provided through a laboratory waveform generator and the output can be monitored using an oscilloscope. Alternately, a microcontroller (or microprocessor) can be used to control the potentiostat circuit. A basic circuit schematic of a microcontroller-controlled potentiostat is presented in Figure 4.

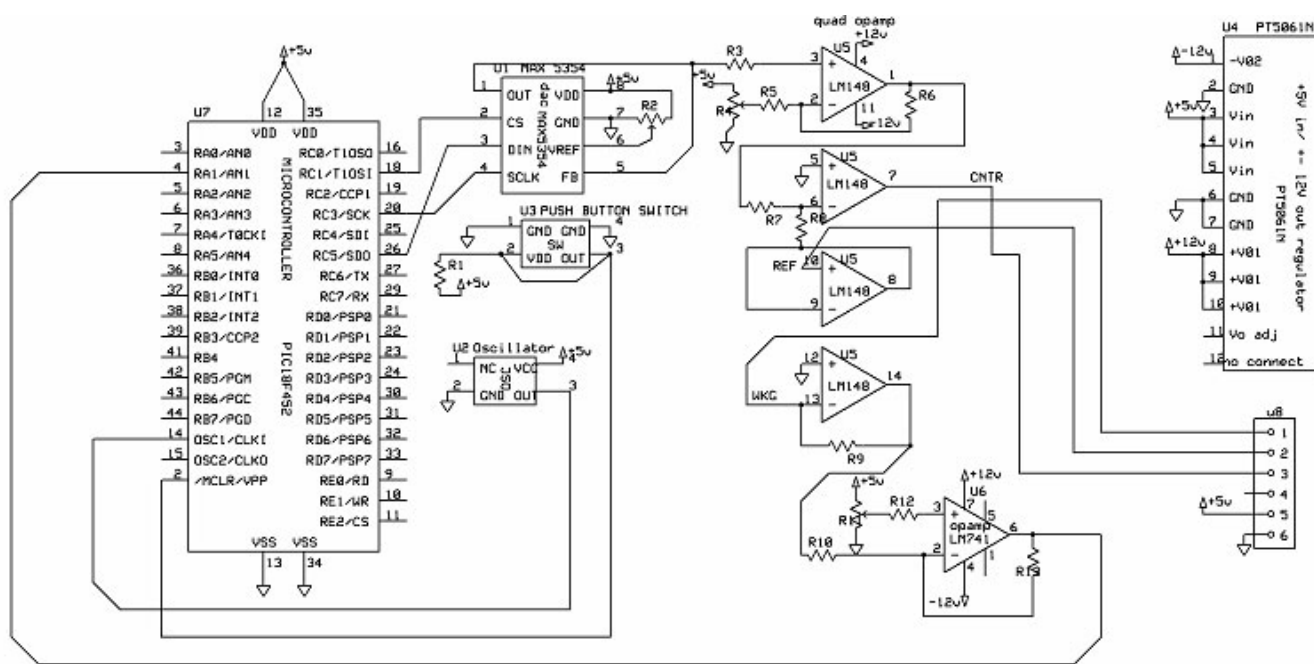

**Figure 5.** Schematic of potentiostat system designed using PIC18F452.

**Table 1.** Parts List with Description

Part	Part No.	Description	Functionality
U1	MAX5354	10-bit serial D/A converter	Converts digital word into analog equivalent
U2	CTX144	4-MHz ceramic resonator	Provides a 4-MHz clock for the potentiostat system. The microcontroller internally divides this by 4 to get a 1-MHz clock
U3	D6C 90	Push button	For external resetting of microcontroller
U4	PT5061	Single-input, dual-output voltage regulator	Provides $\pm 12\text{V}$ required by op-amp circuits
U5 and U6	LM148 and LM741	Quad op-amp package & Op-amp chip	Pre- and post-electrode cell signal processing
U7	PIC18F452	Microcontroller	Provides control for the potentiostat

**Table 2.** Price List for Parts with Digikey Catalog Numbers

Part Number.	Description	Digikey Catalog Information [DIGI04]	Cost
MAX5354	10 bit serial D/A converter	Pg. no.573	\$7.61
CTX144	4 MHz oscillator	Pg. no.722	\$2.78
D6C 90	DPST switch	Pg. no.1089	\$0.94
PT5061	Single input dual output voltage regulator	Pg. no.1319	\$16.20
LM148	Quad op-amp package	Pg. no.522	\$2.98
LM741	Op-amp	na	\$0.54
PIC18F452	Micro-controller	na	\$9.38
Total Cost			\$40.43

The schematic of this microcontroller-based potentiostat is presented in Figure 5. A PIC18F452 microcontroller was used in this project, having an in-built analog-to-digital converter (A/D converter), serial peripheral interface (SPI), and a timer-capture module. The A/D converter is used for measuring the electrochemical current equivalent voltage. The SPI is used for communication between the microcontroller and digital-to-analog converter (D/A converter) and the timer-capture module is used for updating the D/A converter and monitoring the output of the A/D converter at precise time intervals.

A list of the components, a brief description of them, and their functionality is presented in Table 1. The components can be acquired through the Digikey Website and price and catalog numbers are provided in Table 2.

The microcontroller generates a triangular voltage waveform to be fed to the electrochemical cell using a 10-bit up-down counter. The digital output word from the microcontroller is fed to a serial D/A converter using the serial peripheral interface of the microcontroller. The output voltage swing of the serial D/A converter is variable and depends on the voltage on the reference pin ( $V_{\text{REF}}$  pin of the MAX5354). A potentiometer is connected to the  $V_{\text{REF}}$  pin and the output voltage swing of the D/A converter is controlled by changing the potentiometer settings. The output of the serial D/A is unipolar; to change the output voltage to bipolar an op-amp level shifter circuit is used. A buffer is inserted between the counter electrode and the level-shifted voltage; the buffer prevents loading of earlier op-amp stages from the current drawn by the electrochemical cell. The reference electrode is connected to the noninverting terminal of a voltage-

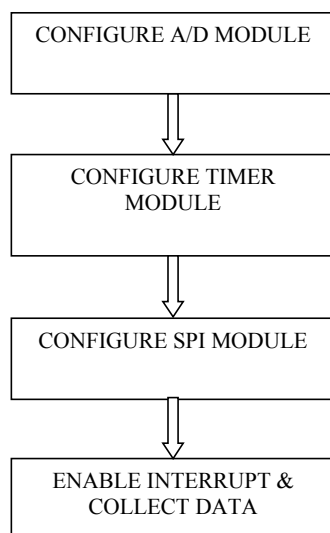

Figure 6. Flow diagram for potentiostat control system.

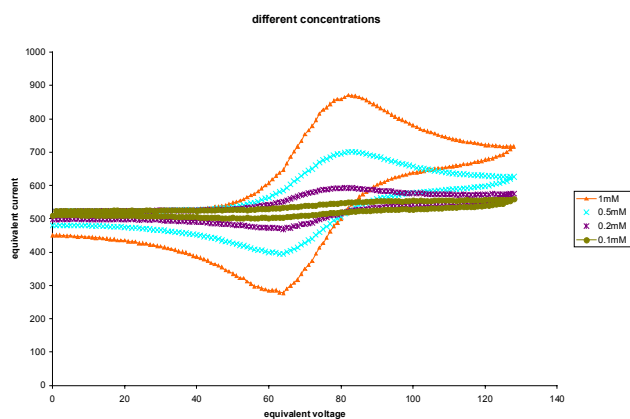

Figure 7.  $i$  versus  $E$  curves for different concentrations.

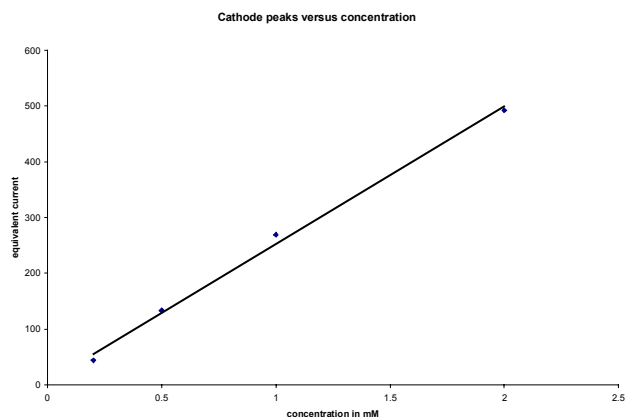

Figure 8. Calibration curve for cathodic peaks of potassium ferricyanide.

follower circuit. The voltage-follower circuit helps in maintaining a constant potential at the reference electrode without drawing much current. The working electrode is connected to the inverting terminal of a current-to-voltage converter; this, in effect, keeps the working electrode tied to ground and also produces a voltage equivalent of the electrochemical current at the output of the voltage converter. The electrochemical current, now converted to a voltage, is level-shifted and attenuated/amplified to bring the voltage into the 0-to-5-V range

acceptable by the microcontroller and fed to the analog input port of the microcontroller.

A basic flow diagram of the potentiostat-control system is presented in Figure 6. The microcontroller uses the timer-capture module to provide interrupts at periodic intervals (the periodicity of these interrupts determines scan rate). During an interrupt, the 10-bit up-down converter values are updated, the A/D measurements are taken, and the serial D/A contents are updated.

**Test Solutions for Potentiostat Performance.** For testing the potentiostat, potassium ferricyanide solution (Mallinkrodt, analytical reagent grade) in 0.1 M potassium nitrate was used. 100  $\mu$ M, 200  $\mu$ M, 500  $\mu$ M, 1 mM, 2 mM, and 5 mM solutions were prepared, and each solution was also made 0.1 mM in sodium hydroxide (Fischer Scientific, certified A.C.S. grade) to eliminate formation of HCN. The potassium nitrate solution serves as an electrolyte to suppress migration so the mass transfer of ferricyanide ion in the electrochemical cell is only by diffusion. All glassware was washed with a 1:10 dilution of  $\text{HNO}_3$  (Fischer Scientific, Certified ACS plus grade) in deionized water. All dilutions were carried out using deionized water and the solutions were stored in cleaned, acid washed poly bottles.

**The Three Electrodes.** The pseudo reference electrode was a silver wire (Alfa Aesar, 0.5-mm diameter Premion™, 99.9985% metal basis). Platinum foil used for the counter and working electrodes is 0.004 inches (0.1 mm) thick Premion (Alfa Aesar, 99.998% metal basis). The working electrode is a small, circular disc with a total surface area of 0.76  $\text{cm}^2$ . The counter electrode is of the same platinum foil material having a total surface area of 1.5  $\text{cm}^2$ .

**Electrochemical Cell Setup for Cyclic Voltammetry.** For this simple, uncomplicated test solution, a 10-mL glass beaker served as the electrochemical cell. The three electrodes were electrically insulated from each other, except for the current path through the electrolyte solution. The scan rate is 100 mV/s (millivolts/second), initial potential was +0.4 V, and switching potential was -0.1 V. The  $i$  versus  $E$  curves for the different concentrations are presented in Figure 7; however, the plot in Figure 8 is not the actual current-versus-voltage curve, it is the data points for voltage and current stored in the microcontroller and hence the axes are named “equivalent voltage” and “equivalent current.” A calibration curve (response vs. analyte concentration) for the cathodic peak of current was generated based on values from the  $i$  versus  $E$  graphs (Figure 8). (The anodic peak currents showed similar linearity with analyte concentration but that plot is not presented here.)

**How To Change the Potential Limits on This Potentiostat.** The output of the serial D/A converter is connected to a level-shifter circuit, shown in Figure 9 which is a blown-up portion of the main schematic (Figure 5). The output voltage,  $V_{\text{out}}$ , at the level-shifter circuit is a function of the input voltages at the negative and positive terminals (i.e., the DC offset voltage and output of the serial D/A converter) and is stated mathematically as

$$V_{\text{out}} = -(R_6/R_5) (\text{DC offset voltage}) \\ + (1 + R_6/R_5) (\text{MAX5354 output voltage})$$

For this project,

$$R_f = R_{\text{in}} = 1 \text{ K}\Omega.$$

$$V_{\text{out}} = - \text{DC offset voltage} + 2 (\text{MAX5354 output voltage})$$

$V_{\text{out}}$  represents the current applied to the electrochemical cell; therefore, the voltage range can be changed by changing the potentiometer settings ( $R_2$ ) connected to the  $V_{\text{REF}}$  pin of MAX5354 and the polarity of the voltage can be changed by varying the potentiometer settings ( $R_4$ ) of the DC offset voltage. Potentiometer settings are easily changed by physically rotating the shaft of the potentiometer. An illustration of the output voltage at the MAX5354

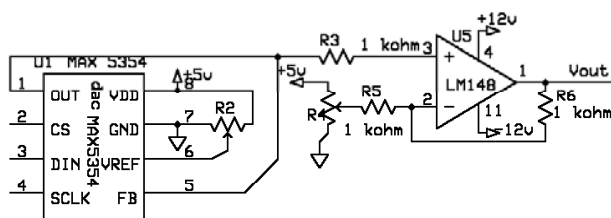

Figure 9. Serial D/A converter and level-shifter amplifier.

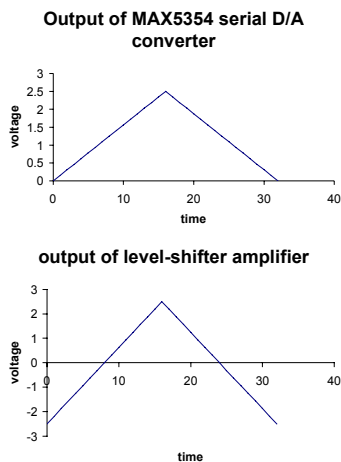

Figure 10. Output voltages of MAX5354 and level-shifter amplifier.

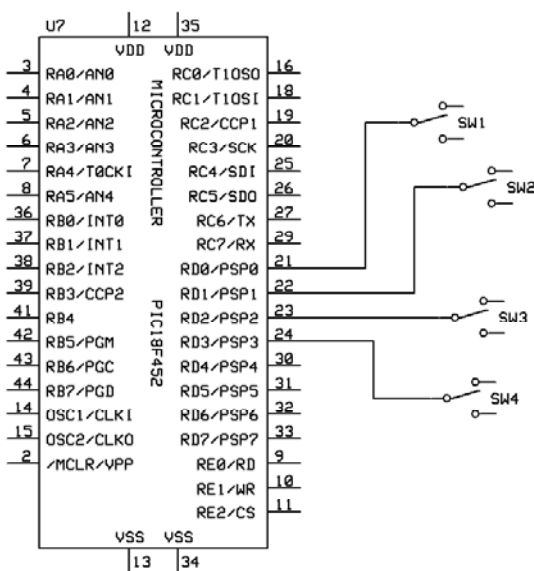

Figure 11. System for changing scan rates.

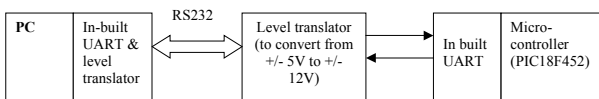

Figure 12. Block diagram for RS232 communication between PC and microcontroller.

and at the level-shifter amplifier circuit, for the current settings of R6 and R5 is presented in Figure 10.

**How To Change Scan Rate.** The potentiostat system as described here does not have this option, so this version of the instrument only

scans at 100 mV/s. The scan rate of the input triangular voltage is determined by the device generating the waveform, in this case the microcontroller. The microcontroller in this project implements the triangular waveform by periodically incrementing (decrementing) a counter (hereafter called the “triangular counter”). By changing this periodicity we can change the scan rate. To determine the periodicity in this project, we preloaded a counter (hereafter “periodicity counter”) with a specific value and decremented it every clock cycle until it reached zero. The triangular counter contents are updated every time the periodicity counter reached zero. So, for changing the scan rate it is only necessary to change the preloaded value. This entire mechanism is implemented in the PIC18F452 using a timer-capture module and the scan rate can be varied by loading different values into the compare register. A scan rate option can be provided to the user by connecting a set of switches to unused I/O ports of the microcontroller as shown in Figure 11 and monitoring the values on these ports prior to initiating a scan. For  $n$  switches, we can have  $2^n$  distinct scan rates.

**How To Interface with RS 232 for PC Control and Data Acquisition.** The RS232 was not implemented on the current version. A RS232 communication protocol can be used to communicate between a PC and the microcontroller. The microcontroller used in this project has a built-in UART (Universal Asynchronous Receiver Transmit) buffer. A look-up table of the chemical concentrations and peak amplitudes for a given set of potentiometer settings, scan rate, and electrode surface area can be programmed into the microcontroller. After each reading, the peak amplitudes can be used to reverse look up the concentration of the chemical and the chemical concentration can be sent out to a PC using RS232 communication protocol. The microcontroller writes the concentration data to its UART buffer, which in turn produces the appropriate RS232 signal and sends it to an inverter and level-shifter circuit, as the RS 232 communication protocol uses  $\pm 12V$  over its cable. The data can be read at the PC by using the HyperTerminal option provided under communications in the start-up menu.

The serial interface between the PIC18F452 and the PC has been tested in the laboratory using arbitrary digital words; a look-up table could also be prepared, but we did not do that here.

A block diagram showing the interconnections between the PC and the microcontroller is presented in Figure 12. A discussion on the block diagram is presented after a brief introduction to the RS232 communication protocol.

The RS232 is a serial asynchronous interface; information regarding RS232 is widely available on the Internet [9]. The RS232 has separate lines for transmitting and receiving data; the two lines idle high when there is no transaction between the PC and the microcontroller. When the microcontroller wants to transmit data to the PC, it performs the following steps:

- Pulls the data line low (logic 0 is implemented as +12V), the receiving terminal (i.e., the PC) synchronizes to the transmitting terminal (i.e., the microcontroller) with this information.
- Sends the 8-bit ASCII data, LSB (least significant bit first).
- Pulls the data line high (logic 1 is implemented as -12V).

A reproduction of the waveform used in reference [10] for transmitting the alphabet ‘A’ is presented in Figure 13.

## Results and Conclusions

The electrochemical experiments demonstrate the functionality of the potentiostat. The cyclic voltammetric curves for the test species ferricyanide have the theoretically predicted shapes for a reversible, one-electron process, described by the Randles–Sevcik equation. Both anodic and cathodic peak currents exhibit a linear correlation with analyte concentration with a correlation factor greater than 0.99. According to the Randles–Sevcik equation



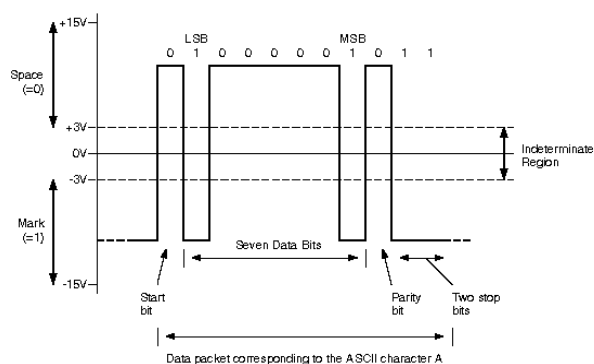

**Figure 13.** Reproduction of RS232 signal for transmitting the character "A."

$$i_p = 2.69 \times 10^5 n^{3/2} AD^{1/2} C \nu^{1/2}$$

where  $i_p$  is peak current (amps),  $n$  is number of electrons in the transfer,  $A$  is surface area of the electrode ( $\text{cm}^2$ ),  $D$  is diffusion coefficient of the species ( $\text{cm}^2/\text{s}$ ),  $C$  is concentration ( $\text{mol}/\text{cm}^3$ ), and  $\nu$  is scan rate ( $\text{V}/\text{s}$ ).

This potentiostat is easy-to-build, and if all the parts are assembled ahead of time, it can be completed in one or two laboratory periods. Preparation of analyte solutions and testing of potentiostat function can be completed in a second laboratory period. The power requirement is minimal and can be supplied by a 9-volt battery, making this potentiostat field-portable. (A 12-volt battery may also be used, if that is more convenient.) This experiment should be useful for advanced analytical students or any students with a working knowledge of simple circuit construction and an interest in electrochemical instrumentation.

The light weight and small footprint of the potentiostat, 3 cm  $\times$  13 cm, (Figure 1) makes it very portable and enables field detection of electroactive species in real time. The potentiostat can be used to analyze either anodic or cathodic peaks or both peaks. There are very few truly reversible electron-transfer reactions. This means that very few systems exhibit linear response with both cathodic and anodic waves. The potentiostat built in this work is not limited in this sense; any reaction that has at least a one-electron transfer process in at least one direction is detectable. The chosen potential range could be sensed and quantified by this method. The potential ranges and the scan rates are easily changed; hence, the potentiostat can operate over a wide range of potential and scan rate.

Options for upgrading this potentiostat have been described, and could be useful for students desiring greater flexibility in using this potentiostat.

#### Appendix: Determining Peaks and Peak Current

The special-events mode of the timer-compare module is used for taking periodic analog-to-digital measurements. Loading different values into the compare register changes the time period between two consecutive A/D measurements. When the timer count equals the contents of the compare register, the go/done bit of the analog-to-digital converter is set, thus initiating an A/D measurement. After the completion

of the A/D conversion, a high-level interrupt is generated. In the interrupt service routine, the analog-to-digital value is read from the A/D conversion registers; 8 contiguous values are averaged to remove noise and are stored in an array of length 256. After completion of a scan (2048 counts, 1024 up counts, and 1024 down counts), the interrupt is disabled and the peak in both directions is computed. The knee of the curve [SALV\_] in each direction is computed and the slope of the left-hand side of the curve is calculated. The peak with respect to slope in each direction is calculated. The microcontroller stores the calibration data of the curves in terms of slope and  $y$  intercept of the best-fit line. The concentration corresponding to the peak current value is determined by using the slope and  $y$  intercept of the calibration curve and an 8-bit data bit value corresponding to the current is generated.

In this work, the baseline current in both anodic and cathodic sweeps is determined by finding the point of maximum curvature between the beginning of sweep and the corresponding peak; a line is then fit through all the points on the left-hand side of the point of maximum curvature. The L method [11] is used to find the point of maximum curvature or knee of a curve.

The peak with respect to the base-line current is calculated in both directions. The concentration of the electroactive chemical species is then extracted from the calibration curve. The calibration curve is formed using a set of standard solutions covering the entire range of possible (or expected) concentrations.

#### References and Notes

1. Reay, R. J.; Kounaves, S. P.; Kovacs, G. T. A. Microfabricated Electrochemical Analysis System for Heavy Metal Detection. Presented at the 8th International Conference on Solid-State Sensors and Actuators and Eurosensors IX, Stockholm, Sweden, June 25–29, 1995, *Digest of Technical Papers*, Vol 2; pp 932–935.
2. Shults, M. C.; Rhodes, R. K.; Updike, S. J.; Gilligan, B. J.; Reining, W. N. *IEEE Trans. Biomed. Eng.* **1994**, *41* (10), 937–942.
3. Bandyopadhyay, A.; Mulliken, G.; Cauwenberghs, G.; Thakor, N. **2002**, *2*, 26–29.
4. (a) Tan, Y.-J. *J. Corrosion Sci. and Engr.* **2005**, *1* (11); (b) Cottis, R. A.; Turgoose, S.; Mendoza, J. Electrochemical noise measurement for corrosion applications. *ASTM STP 1277*; Kearns, J. R., Ed.; 1996; p 93.
5. Russell, D. D.; Meyer, R. L.; Davis, N., G.; Jubran, N.; Moudry, R.; Tokarski, Z.; Lee, H.-K. *J. Imaging Sci. Tech.*, submitted.
6. Hall, S. R.; Milne, B.; Loomis, C. *Anesthesiology* **1999**, *90* (1), 165–173.
7. (a) Armstrong, F. S.; Camba, R.; Heering, H. A.; Hirst, J.; Jeuken, L. J.; Jones, A. K.; Leger, C.; McEvoy, J. P. *Faraday Discuss.* **2000**, *116*, 191–203; (b) Brevnov, D. A.; Finklea, H. O. *J. Electrochem. Soc.* **2000**, *147*, 3461–3466.
8. Bard, A. J.; Faulkner, L. R. In *Electrochemical Methods—Fundamentals and Applications*; Wiley & Sons: New York, 1980; p 566.
9. This is explained extensively at <http://www.arcelect.com/rs232.htm> (accessed Nov 2005).
10. RS232 Data Interface, A Tutorial on Data Interface and Cables. <http://www.arcelect.com/rs232.htm> (accessed Nov 2005).
11. Salvador, S.; Chan, P. Determining the Number of Clusters/Segments in Hierarchical Clustering/Segmentation Algorithms. *Department of Computer Science Technical Report CS-2003-18*, Florida Institute of Technology, 2003.